

CNC MARINE

PROJECT	6100 Walkaround Hard Top		
DRAWING TITLE	General Arrangement		
DWG NO	6100WA-HT-100	REV A	SIZE A3
SHEET 1 OF 2		www.cncmarine.com.au cncmarine@yahoo.com.au	

COPYRIGHT CNC MARINE.

This drawing and the data disclosed herein is not to be reproduced, copied or modified in whole or in part without express written permission from CNC Marine. ALL RIGHTS RESERVED

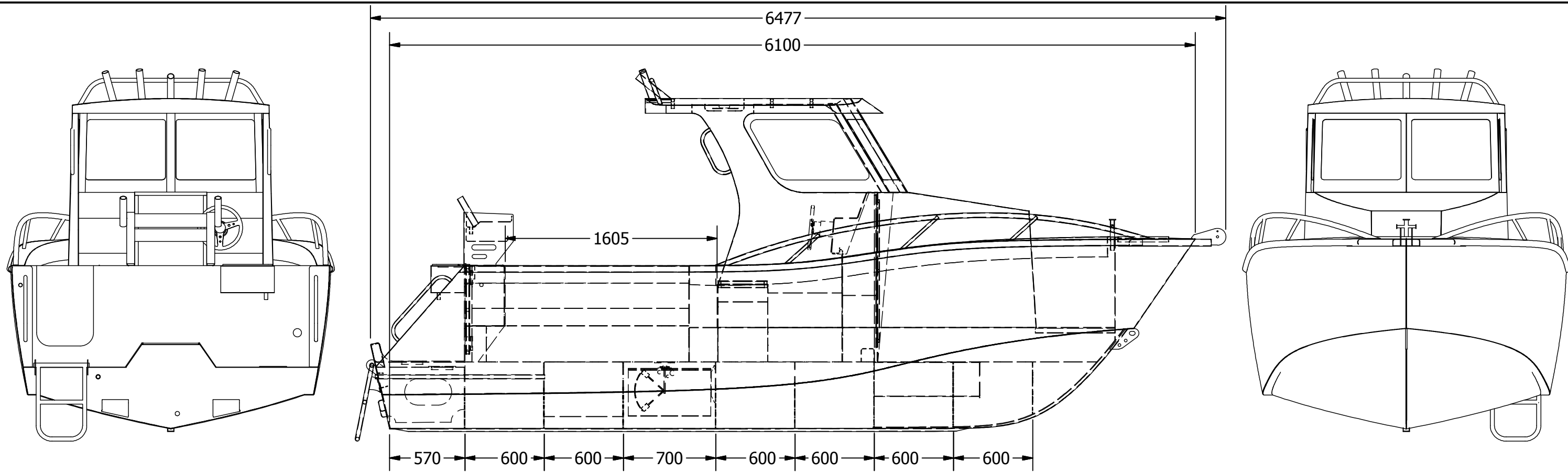

PROFILE
SCALE 1:30

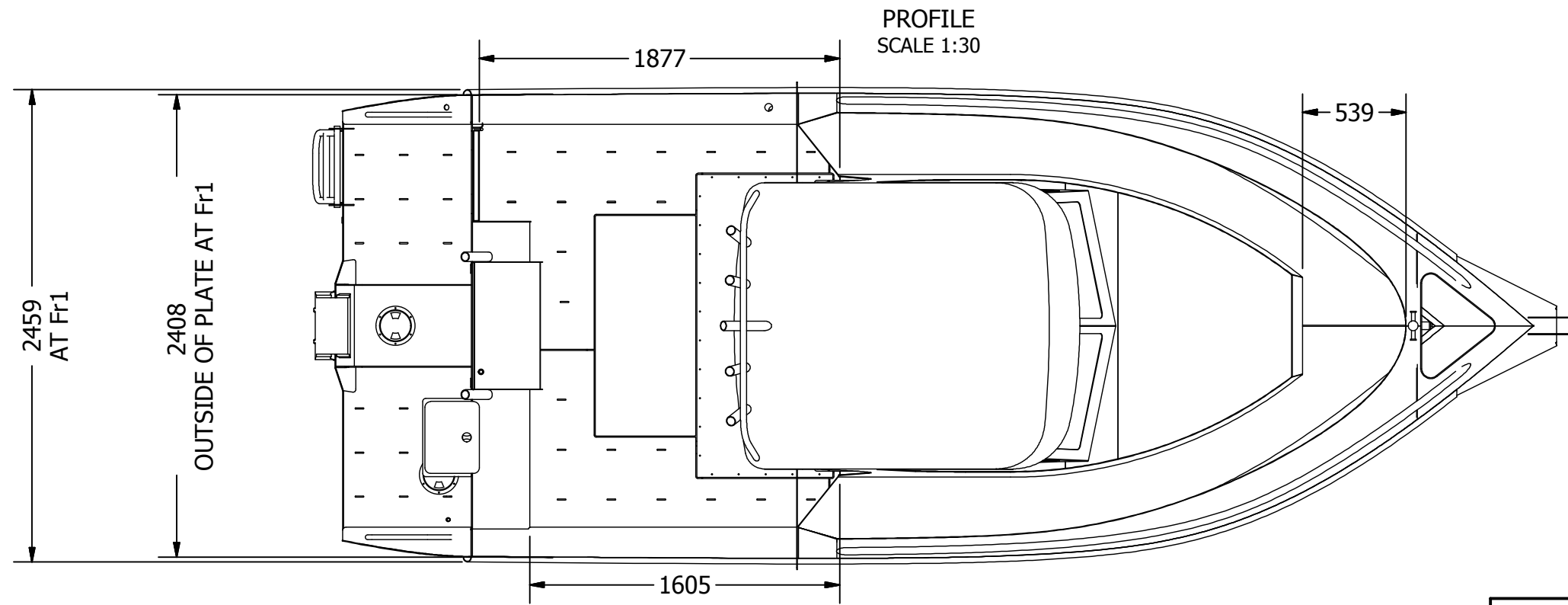

PLAN
SCALE 1:30

NOTES

1. ALL FRAME DIMENSIONS ARE FWD FACE TO FWD FACE (EXCEPT TRANSOM).
2. ALL FRAMES ARE FITTED AFT OF THE LINE (EXCEPT TRANSOM).
3. TRANSOM IS FITTED FWD OF THE LINE.
4. ALL PLATE TO BE MARINE GRADE 5083 H321 ALUMINIUM PLATE.
5. BENDABLE EXTRUSIONS (eg HANDRAILS) TO BE 6060 T52.
6. BUOYANCY FOAM NOT REQUIRED BY AUSTRALIAN BUILDERS PLATE BUT IS RECOMMENDED.
7. WINDSCREEN FOR REFERENCE ONLY. NOT INCLUDED IN KIT.

COPYRIGHT CNC MARINE.

This drawing and the data disclosed herein is not to be reproduced, copied or modified in whole or in part without express written permission from CNC Marine. ALL RIGHTS RESERVED

CNC MARINE			
PROJECT		6100 Walkaround Hard Top	
DRAWING TITLE		General Arrangement	
DWG NO	6100WA-HT-100	REV	SIZE
		A	A3
SHEET 2 OF 2		www.cncmarine.com.au cncmarine@yahoo.com.au	